

TECHNICAL DATA SHEET

Insert fittings for PE pipes: light male adaptor

302

Product description

Fitting with male thread

Product picture



Characteristics

Max. working temperature 60 °C.
 Max. working pressure 4 bar at 20 °C.

Applications

Green house or open field irrigation systems.

Benefits, operation, materials

Connection with LDPE pipes Ø16÷20 PN4.

- Black polypropylene body

Technical design

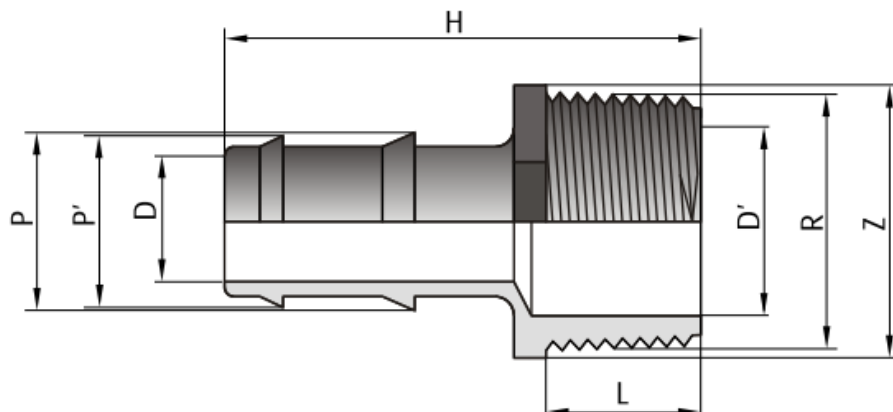

Technical data

Table 1. – Dimensions

P x R	P	P'	R	L	D	D'	H	Z
<i>mm x inch</i>	<i>mm</i>	<i>mm</i>	<i>inch</i>	<i>mm</i>	<i>mm</i>	<i>mm</i>	<i>mm</i>	<i>mm</i>
16 x 3/4"	16	15	3/4"	16	9	17	57	29
20 x 3/4"	20	19	3/4"	16	12	17	57	29

Applicable standards			
Code	Title	Edition	Certificate
UNI EN 10226-1	Pipe threads where pressure tight joints are made on the threads. Part 1: Taper external threads and parallel internal threads - Dimensions, tolerances and designation	January 2006	□

Use and/or assembly instructions

Insert the fitting in the pipe until it stops.

Threaded offtake:

It is recommended to put two turns of teflon on the thread to avoid losses at low pressure.

Packaging

Table 2.

Size	Pack	Box	Type
16 x 3/4"	-	1000	C
20 x 3/4"	-	800	C

Notes and annexes